

ROYAL MASTER

Revision : 2007.6.

Royal Master Hydraulic Pump Units
(for Double Acting Type Royal Punchers)

Instruction Manual

Models

D-3SW

D-2SW-4

D-1SW-4

1SW-40



Sankyo Co., Ltd.

1-7-1, Fushiki-kokubu, Takaoka City, Toyama Pref., 933-0101, Japan

TEL: 81-766-44-0924

FAX: 81-766-44-2127

CONTENTS

1. To ensure safe operation of the hydraulic pump unit, be sure to first read the following instructions:	3
2. Specifications of the Hydraulic Pump Unit	4
3. Name of Each Part	4
4. Installation Place	5
5. Preparations before Use	5
6. Pump Operation Procedure	6
7. Operating Precautions	7
8. Precautions after Use	7
9. Inspection and Maintenance	8
10. Circuit Diagram	9

SAFETY PRECAUTIONS FOR ROYAL MASTER HYDRAULIC PUMP UNITS

1. To ensure safe operation of the hydraulic pump unit, be sure to first read the following instructions:

The following provides important safety instructions that must always be observed in installing, operating and inspecting the motor-driven hydraulic pump unit(s).



1) Be sure to read the instruction manual for hydraulic equipment to be used in combination with this pump unit, and make sure that there is no problem in its mechanical combination. If, for instance, the operating pressure differs between the pump unit and the hydraulic equipment, then the equipment or the connecting pipes and/or hoses may be damaged, resulting in a serious accident or injury or even death in the worst case.



2) This pump unit generates an ultra-high pressure of 72 MPa (740 kg/cm²), requiring selection of hydraulic hoses and connecting joints that are strong enough to withstand such a high pressure. If they are not strong enough in terms of withstanding the pressure, they may be damaged.



3) When removing the cover from the electric equipment for servicing or maintenance purposes, or when checking the power circuit and the operating switch circuit(s), be sure to turn OFF the mains power before doing so. Working on the pump unit with power ON will create an electric shock hazard.



4) Do not change the set pressure or modify the pump unit without our prior approval. Doing so may result in an accident or a failure of the unit. If repairs are necessary, contact the dealer you purchased the unit from. Repairs by unauthorized personnel may lead to a fatal damage to the pump unit.

2. Specifications of the Hydraulic Pump Unit

Specifications \ Model		D-3SW	D-2SW-4	D-1SW-4	1SW-40
Motor		2.2 kW AC380V, 50Hz AC415V, 50Hz 3-phase	1.5 kW AC380V, 50Hz AC415V, 50Hz 3-phase	0.75 kW AC380V, 50Hz AC415V, 50Hz 3-phase	0.4 kW AC220V, 50Hz AC230V, 50Hz Single phase
Pressure	High pressure	72 MPa (720 bar)			
	Low pressure	7 MPa (70 bar)			3 MPa
Discharge rate *	High pressure	2.3 L/min	1.5 L/min	0.75 L/min	0.3 L/min
	Low pressure	5.8 L/min	3.75 L/min	3.75 L/min	1.9 L/min
Reservoir capacity (liters)		12	10	7.5	5
Weight		65 kg	55 kg	38 kg	28 kg
Solenoid-Valve		3-position, 4-way			2-position, 4-way

Working oil: ISO VG #32

* Discharge rate for 50 Hz. 60 Hz provides a discharge rate increased by about 20%.

3. Name of Each Part

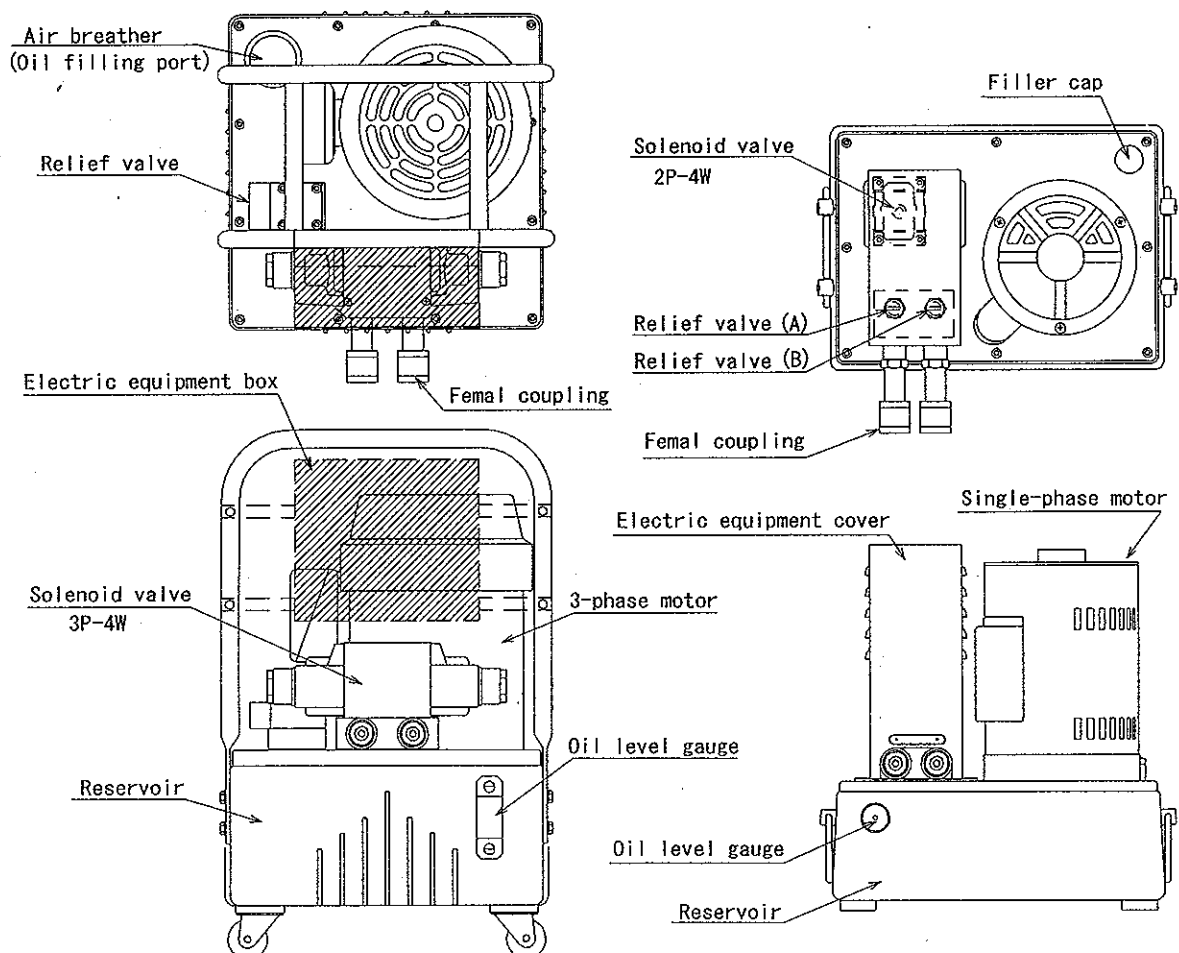

4. Installation Place



- 1) Since this pump unit is not structured to be waterproof and dustproof, avoid installing it in a place exposed to rain or large amounts of dust. Model 1SW-40 in particular is of a structure having a motor exposed outside, thus requiring its installation in a place exposed to no splashing water. Furthermore, dust and water may cause insulation failure, leading to a pump failure.
- 2) Install the unit in as flat a place as possible.
- 3) Avoid long hours of use in a place exposed to direct sunlight, or do not leave the unit in such an environment because the working oil temperature may rise extremely.

5. Preparations before Use

1) Replacing the oil filler cap (for Models D-1SW-4 and 1SW-40)

Remove the metal plug from the oil filler port that was fitted at the time of shipment, using a spanner, and then replace it with the attached Red oil cap. Using the metal plug fitted as is causes a negative pressure inside the reservoir or an excessively high pressure, creating a problem.

Models D-2SW-4 and D-3SW are equipped with an air breather instead of a metal plug, thus requiring such a replacement.

2) Connecting hydraulic hoses to the unit

The pump discharge port screw is Rc3/8 in size, and wind a sealing tape around the male threaded sections of the connecting hoses and of the coupling, and screw them into the pump unit for firm connection.

If the unit is delivered with a coupling fitted at our factory:

- * Pressure port (A) : Female coupling (black)
- * Return port (B) : Male coupling (white)

Match the color of each coupling, connect the male coupling to the unit, and screw in the cap nut of the female coupling to its end.

3) Checking the working oil level

Check that the oil level is above the centerline of the oil level gauge. If not so, replenish the following oil brand accordingly.
(Oil used: ISO VG #32)

4) Connecting to the power supply

- (1) Check that the supply voltage and the number of phases are correct.
- (2) To ensure safety, be sure to connect the earth circuit using the grounding wire (green).
- (3) If an extension cord is to be used for connecting to the power supply, select one that is as short in length as reasonably possible, and that has a sufficient capacity.
- (4) The rotating direction of the 3-phase motor is indicated by the arrow. If it is in the other way around, exchange the two wires excluding the grounding wire, with each other to attain the correct rotating direction.

5) Connecting the operation circuit

Connect the 3P rubber connector for operation to the rubber connector for the operation switch (optional).

Electric equipment box for Models D-1SW-4, D-2SW-4 & D-3SW

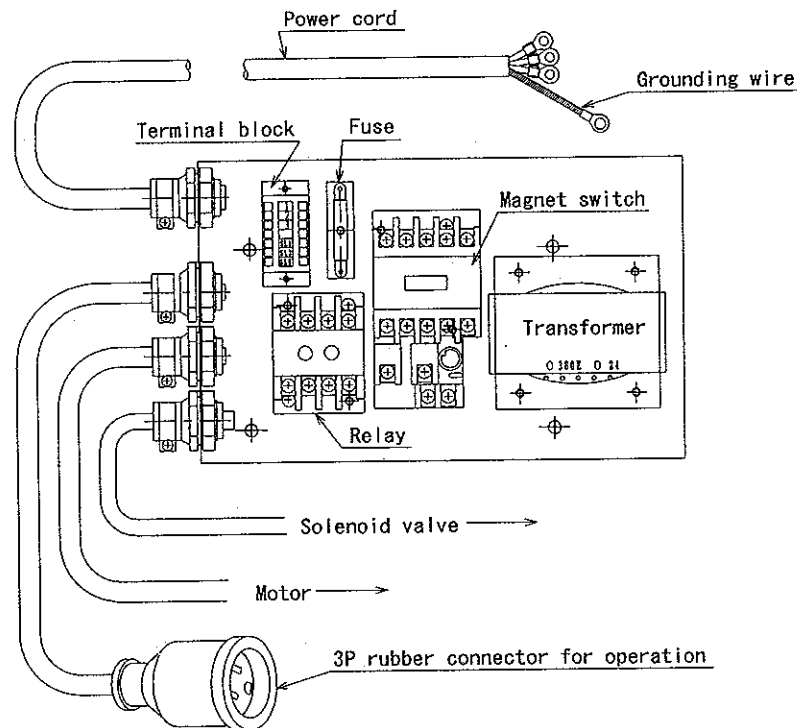

6. Pump Operation Procedure

For the 3-position 4-way solenoid valve (for Models D-1SW-4, D-2SW & D-3SW)

The operation circuit voltage is AC24V.

- 1) While the operation switch (A) is depressed, the motor and the solenoid A are energized, discharging hydraulic oil from Port A.
- 2) While the operation switch (B) is depressed, the motor and the solenoid B are energized, discharging hydraulic oil from Port B.
- 3) Upon releasing both operation switches (A & B), power will be stopped from being supplied, simultaneously stopping the motor and shifting the solenoid valve to the neutral position to stop discharging hydraulic oil.

For the 2-position 4-way solenoid valve (Model 1SW-40)

The operation circuit voltage is the same as the supply voltage.

- 1) While the operation switch (A) is depressed, the motor and the solenoid A are energized, discharging hydraulic oil from Port A.
- 2) While the operation switch (B) is depressed, the motor is energized, discharging hydraulic oil from Port B.
- 3) Upon releasing both switches (A & B), power will be stopped, and the motor will also stop accordingly, shifting the solenoid valve to the B-port position. However, while the motor is running with inertia, hydraulic oil is continuously discharged from Port B.

7. Operating Precautions



The following instructions are important and must therefore be observed in operating the pump unit. Failure to do so may cause serious damage to the hydraulic pump and the equipment used together.

- 1) If the motor beats and fails to run, or runs abnormally slow, then it may be running under single phase (this phenomenon is applicable to a 3-phase motor pump unit). Note that continuing to press the operation switch with open phase will cause the motor to burn. So, if the motor is in such a condition, immediately stop the motor and check the power fuse, power plug, power cord, etc. and correct the open-phase circuit.
- 2) If the supply voltage drops or the extension cord capacity is insufficient, the thermal relay of the magnet switch may operate, making the motor inoperable any longer (this is applicable to a 3-phase motor pump unit). Since the thermal relay is designed to automatically reset, it will reset in about 10 minutes. If a similar phenomenon occurs again, investigate causes before use.
- 3) If the supply voltage drops at Model 1SW-40, the governor for starting the motor will start chattering or power will continue to run to the auxiliary winding, as a result of which the motor speed will not increase any longer. Continuing to operate the pump unit as it is will burn the motor or the solenoid coil. Therefore, suspend the operation and investigate to remove all causes.
- 4) The hydraulic pump unit is equipped with relief valves for overpressure prevention. Although the pressure is set at 80 MPa, use the unit at below 72 MPa for normal operation. As mentioned, the relief valves are intended for prevention of the pump itself and the hydraulic equipment, and therefore if these valves continue to operate, the oil temperature will rise, causing a failure of the pump unit and/or the hydraulic equipment.
- 5) The working oil temperature range of the hydraulic pump is between 10°C and 65°C and therefore it should be used in this range. Use at a temperature exceeding 70°C will cause more serious oxidation of the working oil, accelerating deterioration of packings used in the hydraulic pump unit and hydraulic equipment, and leading to their possible failure.

8. Precautions after Use

- 1) After punching work for the day, for instance, is done, turn off the pump unit.
- 2) When disconnecting the coupling, release the pressure from inside the hydraulic circuit only after moving the hydraulic cylinder (puncher) to the middle position and checking that none of the hoses are under tension any longer. Or, manually press either of the top solenoid center sections of the solenoid valve to release the pressure.

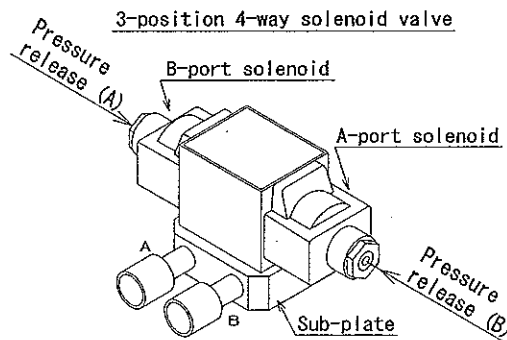

9. Inspection and Maintenance

1) Oil change

- a) Change the working oil usually every six months or every year. If the pump unit is used frequently or it is often used in a condition of a serious temperature rise of the working oil, then change the oil earlier than suggested.
- b) If water has mixed into the working oil, immediately change it entirely. Using the oil with water mixed in will wear and rust pump internal parts.
- c) The working oil uses ISO VG #32 wear-resistant oil for high-pressure service. If the oil temperature rises unusually, use of ISO VG #46 is recommended. Take care never to have automobile brake oil or spindle oil mixed into the working oil because the pump unit may fail.
- d) When using the unit in a place exposed to a lot of dust, clean the suction strainer inside the reservoir at the time of oil change.

2) Setting the relief valve pressure



The maximum set pressure is 80 MPa. To set the relief valve set pressure, be sure to use a pressure gauge and set it to the desired value while checking the pressure reading on the gauge.

If the hydraulic pump unit should be operated with the relief valve being in a fully cutoff condition, the pressure will continue to rise until any item of hydraulic equipment is damaged, or injuries or death may be caused depending on the situation.

- a) Install a pressure gauge halfway to the A-port circuit.
- b) Dismantle the relief valve cover, and loosen the lock nut.
- c) While checking the pressure gauge reading, turn the adjusting screw in gradual degrees for pressure adjustment. Turning it clockwise and counterclockwise respectively increases and decreases the pressure.
- d) Upon completing the pressure setting, be sure to retighten the lock nut for prevention against loosening, and check the set pressure with the pressure gauge again.

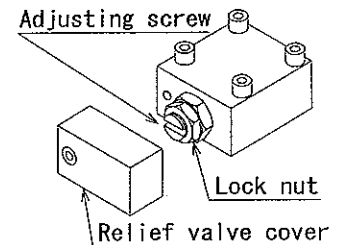

3) Overhauling the pump unit

- a) Periodic overhaul is recommended to be performed once every two years or so, which will extend the service life of the pump unit and provide many years of reliable operation.
- b) If the pump was operated with water mixed in the oil tank (or reservoir), it is necessary to overhaul the pump unit to check and clean the pump interior in addition to changing the oil with a new one. In such a case, overhaul the unit despite the above recommended frequency of periodic overhaul.
- c) To request for overhaul and repair services, contact the dealer you purchased the unit from. Since the pump unit uses precision parts made of special material inside, poor repairs may lead to a serious failure of the pump unit.

10. Circuit Diagram

The circuit is similar in the case of the different power supply voltage.

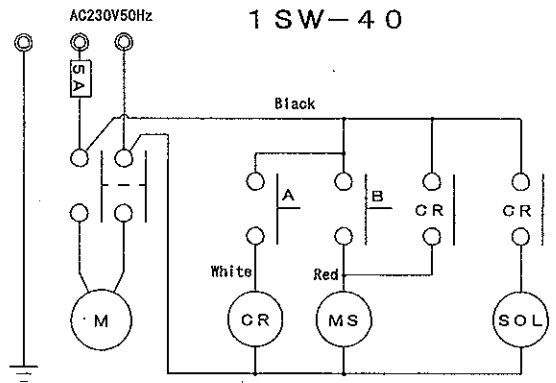
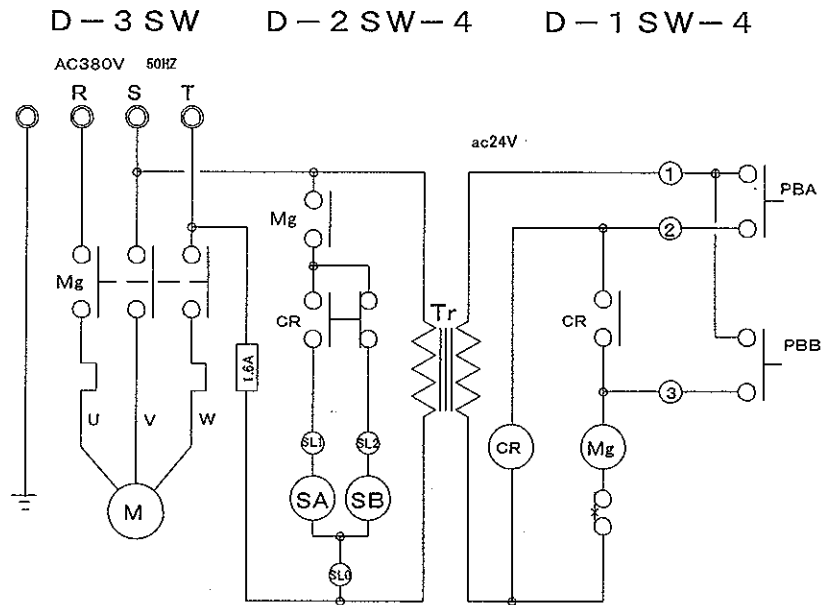

MS : Magnet switch
 CR : Relay
 SA : A-port solenoid
 SB : B-port solenoid

D-3 SW
 D-2 SW-4
 D-1 SW-4

1 SW-40

